

Venue Rider KIFF AARAU Saal

THANK YOU FOR READING OUR VENUE RIDER. IT HAS BEEN LAST UPDATED ON DECEMBER 22, 2025. WE ARE LOOKING FORWARD TO WORKING WITH YOU!

DIMENSIONS & CONSTRUCTION

VENUE

| | |
|----------|---|
| SIZE | 320M ² |
| WIDTH | 16M |
| DEPTH | 20M |
| HEIGHT | 3.7M |
| CAPACITY | 550 PEOPLE STANDING / 140 PEOPLE SEATED |

ELEVATOR

| | |
|----------------|--|
| | PLEASE NOTE THAT THE VENUE IS LOCATED ON THE SECOND FLOOR OF THE BUILDING. LOADING ACCESS VIA ELEVATOR OR STAIRCASE. PLEASE TAKE NOTE OF THE ELEVATORS DIMENSIONS: |
| HEIGHT | 2.1M |
| DOOR WIDTH | 0.9M |
| ELEVATOR WIDTH | 1.1M |
| LENGTH | 1.4M |
| MAXIMUM LOAD | 630KG |

STAGE

| | |
|----------------------------|---|
| STAGE SIZE | 45M ² |
| STAGE WIDTH | 9M |
| STAGE DEPTH | 5M |
| STAGE HEIGHT | 0.75M |
| DISTANCE STAGE – FOH | 11M |
| STAGE CONSTRUCTION | NIVTEC PLATFORMS, 2x1M |
| CLEARANCE HEIGHT AUDIENCE | 3.47M |
| PORTAL/CLEARANCE HEIGHT | 2.75M ABOVE STAGEFLOOR = 3.5M ABOVE AUDIENCE |
| SIDESTAGE LEFT | 1x3M (STAGE ACCESS DRESSING ROOMS) |
| SIDESTAGE RIGHT | 4x4M |
| DEAD CASE STORAGE | SEPARATE ROOM, 1X4M, EASILY ACCESSIBLE SIDESTAGE LEFT |
| BACKDROP AND SIDE CURTAINS | BLACK MOLTON |
| FRONT CURTAIN | BLACK MOLTON, TRAVELER (GREEK-STYLE) |
| STAGE-RISERS | |
| PLATFORM | 8 NIVTEC PLATFORMS, 2x1M |

PLATFORM HEIGHT VARIABLE: 22CM; 35CM; 47CM; 60CM; 100CM; 110CM; 125CM

RIGGING

TOPLIGHT POSITION HEIGHT 2 MOVING TRUSS 2.8x3.6M WITH 4.8CM BARS
MAXIMUM 3.85M ABOVE STAGE FLOOR

BACKLIGHT POSITION HEIGHT SINGLE 4.8CM BAR ACROSS THE STAGE
2.75M ABOVE STAGE FLOOR

FRONTLIGHT POSITION HEIGHT SEVERAL SINGLE 4.8CM BARS ACROSS THE STAGE
2.75M ABOVE STAGE FLOOR

RIGGING AUDIENCE HEIGHT SEVERAL 4.8CM BARS
3.5M ABOVE THE FLOOR

BACKSTAGE/DRESSING ROOMS

BACKSTAGE ONE FLOOR BELOW THE STAGE, 47M²
BACKSTAGE ENTRY & DIRECT ACCESS TO THE STAGE

TOILETS 3 EUROPEAN-STYLE TOILETS, WARM WATER

SHOWER 2 SHOWERS WITH WARM WATER

SOUND

SWISS LOUDNESS LAW

PLEASE NOTE THAT ACCORDING TO A STRICT SWISS LAW RESPECTIVE THE LOUDNESS, NO BAND SHALL EXCEED **LEQ 100 DB(A) OVER 60 MINUTES**, AND THE TOPS NEVER EXCEED THE LIMIT OF **125 DB(A) AT ANY TIME**.

WE THANK YOU IN ADVANCE FOR YOUR COOPERATION!

PA

FRONT SPEAKERS

8 L-ACOUSTICS KARA II
8 L-ACOUSTICS SB18
1 L-ACOUSTICS 112P

LINE ARRAY TOP
CARDIOID SUB SETUP
CENTERFILL

AMPS

4 L'ACOUSTICS LA8
1 C-AUDIO SR404

TOP + SUB
SPARE

REAR SPEAKERS

2 L'ACOUSTICS ARCS WIFO

TOP

AMPS

1 L'ACOUSTICS LA8

MONITORING

16 SENDS FROM FOH, 8 AMP-CHANNELS

SPEAKERS

9 OUTLINE STAGE 15PLUS 350W
1 KLING&FREITAG CA1001
1 DVR MACSUB 615

WEDGES
DRUMFILL TOP
DRUMFILL SUBWOOFER

AMPS

3 C-AUDIO SR 606
1 TRACE ELLIOT PPA 1200

MON 1-6
MON 7-8

FOH

| | |
|--------------------|--|
| DESK | YAMAHA CL3 (64 MONO & 8 STEREO IN/ 32 MONO OUT) |
| STAGEBOX/MULTICORE | 48 INPUTS ON MAIN STAGEBOXES (1X RIO 3216-D, 1X RIO 1608-D) 2 SUB STAGEBOXES (8 CHANNEL) 2 SUB STAGEBOXES (16 CHANNEL) 16 RETURNS ON MAIN STAGEBOX 3 FREE DIRECT CAT5E ETHERCON CONNECTIONS FOH – STAGE (FOR AUDIO OR LIGHTS) |
| PLAYBACK/RECORDING | 1 APPLE MAC MINI WITH ITUNES/TIDAL/LOGIC 1 3.5MM JACK FOR IPODS/PHONES |

SOUND SOURCES

| | |
|----------------------|---|
| WIRELESS MICROPHONES | 3 SHURE ULX-D SM58 |
| WIRED MICROPHONES | 5 SHURE SM58 3 SHURE BETA58 1 SE ELECTRONICS V7 1 AUDIX OM7 1 SENNHEISER E835 1 SENNHEISER E935 9 SHURE SM57 1 SHURE BETA57A 1 SHURE BETA91 1 SHURE BETA91A 1 SHURE BETA52 1 AKG D112 5 SHURE SM81 4 SHURE BETA98 4 EV N/D408 5 SENNHEISER E604 1 SENNHEISER MD441U 1 SENNHEISER MD421 1 SENNHEISER E609 1 SENNHEISER E906 |

| | |
|------------|--|
| D.I. BOXES | 6 BSS AR-133 ACTIVE DI BOX 3 COUNTRYMAN 85-FET DI BOX 1 PALMER PLI-01 MONO LINE ISOLATION BOX 2 PALMER PLI-02 STEREO LINE ISOLATION BOX 2 PALMER PAN 01 (PASSIVE) 1 FOUR CHANNEL DI BOXES (PALMER ACTIVE) |
|------------|--|

| | |
|-------------------|---|
| MICROPHONE STANDS | 11 TALL K&M STANDS 16 SHORT K&M STANDS |
|-------------------|---|

POWER

BACKLINE POWER

HUMM-FREE, SEPERATED FROM LIGHTS
230V, 13A SWISS "T13" POWER SOCKETS
1 CEE32 (SR)
1 CEE16 SINGLE PHASE (BEHIND STAGE)
1 230V-110V TRANSFORMER

POWERBOARDS

SWISS "T13" POWERBOARDS
GERMAN/EUROPEAN "SCHUKO" POWERBOARDS
AMERICAN 110V POWERBOARDS WITH 1 TRANSFORMER

DJING

DJ MIXER

1 ALLEN & HEATH XONE 92
1 PIONEER DJM 900-NXS

CD-PLAYER

2 PIONEER CDJ2000-NXS

TURNTABLES

4 TECHNICS SL-1210 WITH ORTOFON DJ-S PICKUPS

LIGHTS

BASIC LIGHTING SETUP

| | |
|----------------------------------|---|
| FRONTLIGHT | 2 PC SPOTS 1KW 2 FRESNEL SPOTS 1KW 4 FRESNEL SPOTS 500W |
| TOPLIGHT | 6 MARTIN MAC AURA WASHLIGHTS 6 CLAY PAKY AXCOR SPOT 400 4 SIXBAR PAR64 CP61 2 SETS OF FOUR BAR ACL-PAR64 2 FRESNEL SPOTS 1KW 2 FRESNEL SPOTS 2KW 2 MARTIN ATOMIC STROBE 3KW |
| BACKLIGHT | 4 DUAL BLINDERS 1.3KW |
| SIDELIGHT | 2 SPOTLIGHT PROFILERS 1000W 2 FOUR BAR PAR30 |
| FLEXIBLE (FLOOR OR RIG USAGE) | 4 ROBE ROBIN DLX MOVINGHEAD SPOTS 8 MARTIN RUSH PAR 1 RGBW 1 MARTIN ATOMIC STROBE 3KW |
| HAZE | 1 SMOKE FACTORY TOUR HAZER II V.2 |
| AUDIENCE | 12 MARTIN RUSH PAR 1 RGBW 21 PAR30, LED (COLUMNS) 2 DUAL BLINDERS 1.3KW 3 AMERICAN DJ QUAD PHASE HP 1 SMOKE FACTORY DATA 2 SMOKE MACHINE |

ADDITIONAL LUMINARIES

| | |
|----------|--|
| PARS | 6 PAR64 CP62 FLOOR SHORT NOSE 1 SET OF FOUR BAR ACL-PAR64 |
| BLINDERS | 6 SUNSTRIP ACTIVE DMX 10x50W, 1METER |
| UV | 2 UV GUN 100W |
| FANS | 3 TALL 1 MID 2 SMALL |

FOH & POWER

| | |
|----------------|---|
| DESK | AVOLITES ARENA |
| POWER SUPPLY | 3 CEE32 (BEHIND STAGE/IN 5M RANGE TO THE STAGE) 1 POWER DISTRIBUTOR CEE32 TO CEE16 (FLEXIBLE) 1 POWER DISTRIBUTOR CEE32 TO CEE16 (FIX BEHIND STAGE) |
| DIMMER | 6 FREE DIMMER CHANNELS |
| DMX UNIVERSES | UNIVERSE A: FIX ON STAGE (SEE PATCH) UNIVERSE B: FLEXIBLE ON STAGE (SEE PATCH) UNIVERSE C: AUDIENCE (SEE PATCH) TIELINE A (FOH-STAGEBACK CENTER) TIELINE B (FOH-STAGEBACK CENTER) |
| ETHERCON LINES | 3 FREE CAT5 CONNECTIONS FOH – STAGE (FOR LIGHTS OR AUDIO) |

VIDEO

| | |
|-------------|---|
| PROJECTOR | 3 CASIO XJ-V110W (DLP, 3500 ANSI LUMEN) |
| SCREEN | 1 STUMPFL 2.2x2.9M MOBILE FRONTPRO 1 4x3M FRONTPRO (MOUNTED IN THE AUDIENCE) |
| CONNECTIONS | 5 VGA CONNECTIONS FROM FOH TO VIDEO INPUT AND OUTPUT POSITIONS |

FURTHER QUESTIONS?

THE VENUE TECHNICIAN CREW IS LOOKING FORWARD TO WORKING WITH YOU!
IF YOU HAVE FURTHER QUESTIONS, DON'T HESITATE TO CONTACT US

| | |
|---------|------------------|
| E-MAIL: | TECHNIK@KIFF.CH |
| PHONE: | +41 62 822 16 36 |
| WEB: | WWW.KIFF.CH |

DMX Patch Saal 2025

All dimmer channels, fixtures and sockets on stage:

All fixtures that are flexible on stage:

All fixtures and sockets in audience area (venue):

Please make sure everything is in initial condition at the end of the day. Thank you!

Universe A

Universe B

Universe C

CONVENTIONAL LIGHT

| Adress | Manufacturer | Fixture | Mode | Chan. | Position | Fixture ID |
|--------|--------------|-----------------|------|-------|---------------------|------------|
| 1.001 | Dimmer | 2 x PAR64 | | 1 | Backtruss 1 | 1 |
| 1.002 | Dimmer | 2 x PAR64 | | 1 | Backtruss 1 | 2 |
| 1.003 | Dimmer | 2 x PAR64 | | 1 | Backtruss 1 | 3 |
| 1.004 | Dimmer | 2 x PAR64 | | 1 | Backtruss 1 | 4 |
| 1.005 | Dimmer | 2 x PAR64 | | 1 | Backtruss 1 | 5 |
| 1.006 | Dimmer | 2 x PAR64 | | 1 | Backtruss 1 | 6 |
| 1.007 | Dimmer | 2 x PAR64 | | 1 | Midtruss 1 | 7 |
| 1.008 | Dimmer | 2 x PAR64 | | 1 | Midtruss 1 | 8 |
| 1.009 | Dimmer | 2 x PAR64 | | 1 | Midtruss 1 | 9 |
| 1.010 | Dimmer | 2 x PAR64 | | 1 | Midtruss 1 | 10 |
| 1.011 | Dimmer | 2 x PAR64 | | 1 | Midtruss 1 | 11 |
| 1.012 | Dimmer | 2 x PAR64 | | 1 | Midtruss 1 | 12 |
| 1.031 | Dimmer | 2x 4 BAR ACL | | 1 | Midtruss Off | 41 |
| 1.032 | Dimmer | 2x 4 BAR ACL | | 1 | Midtruss Center | 42 |
| 1.013 | Dimmer | Fresnel 500W | | 1 | Frontrig 1 Audi | 21 |
| 1.014 | Dimmer | Fresnel 500W | | 1 | Frontrig 1 Audi | 22 |
| 1.015 | Dimmer | Fresnel 500W | | 1 | Frontrig 1 Audi | 23 |
| 1.016 | Dimmer | Fresnel 500W | | 1 | Frontrig 1 Audi | 24 |
| 1.017 | Dimmer | 2 x Fresnel 1KW | | 1 | Frontrig 2 Audi | 25 |
| 1.018 | Dimmer | 2 x Fresnel 1KW | | 1 | Frontrig 2 Audi | 26 |
| 1.025 | Dimmer | Fresnel 1KW | | 1 | Fronttruss Center | 28 |
| 1.026 | Dimmer | Fresnel 1KW | | 1 | Fronttruss Center | 29 |
| 1.027 | Dimmer | Fresnel 2KW | | 1 | Fronttruss Off L | 30 |
| 1.028 | Dimmer | Fresnel 2KW | | 1 | Fronttruss Off R | 31 |
| 1.029 | Dimmer | Profile | | 1 | Alleylight Front SR | 32 |
| 1.030 | Dimmer | Profile | | 1 | Alleylight Front SL | 33 |
| 1.039 | Dimmer | 4 BAR PAR 30 | | 1 | Alleylight SR | 34 |
| 1.040 | Dimmer | 4 BAR PAR 30 | | 1 | Alleylight SL | 35 |

CONVENTIONAL LIGHT

| Adress | Manufacturer | Fixture | Mode | Chan. | Position | Fixture ID |
|--------|--------------|---------|------|-------|--------------------|------------|
| 1.033 | Dimmer | Blinder | | 1 | Backdroprig SR | 51 |
| 1.034 | Dimmer | Blinder | | 1 | Backdroprig SRC | 52 |
| 1.035 | Dimmer | Blinder | | 1 | Backdroprig SLC | 53 |
| 1.036 | Dimmer | Blinder | | 1 | Backdroprig SL | 54 |
| 1.041 | Dimmer | Blinder | | 1 | Frontrig 0/Curtain | 55 |
| 1.038 | Dimmer | Blinder | | 1 | Frontrig 0/Curtain | 56 |

FREE DIMMER CHANNELS

1.042-1.048 Dimmer

KIFF AARAU

WASHES

| Adress | Manufacturer | Fixture | Mode | Chan. | Position | Fixture ID |
|--------|--------------|----------|---------------------|-------|----------|------------|
| 1.061 | Martin | Mac Aura | Standard (Col. OFF) | 14 | Rig SR | 201 |
| 1.075 | Martin | Mac Aura | Standard (Col. OFF) | 14 | Rig SRC | 202 |
| 1.089 | Martin | Mac Aura | Standard (Col. OFF) | 14 | Rig SRL | 203 |
| 1.103 | Martin | Mac Aura | Standard (Col. OFF) | 14 | Rig SLR | 204 |
| 1.117 | Martin | Mac Aura | Standard (Col. OFF) | 14 | Rig SLC | 205 |
| 1.131 | Martin | Mac Aura | Standard (Col. OFF) | 14 | Rig SL | 206 |

SPOTS

| Adress | Manufacturer | Fixture | Mode | Chan. | Position | Fixture ID |
|--------|--------------|----------------|----------------|-------|----------|------------|
| 1.221 | Clay Paky | Axcor Spot 400 | 28 DMX | 28 | Rig SR | 101 |
| 1.249 | Clay Paky | Axcor Spot 400 | 28 DMX | 28 | Rig SRC | 102 |
| 1.277 | Clay Paky | Axcor Spot 400 | 28 DMX | 28 | Rig SRL | 103 |
| 1.305 | Clay Paky | Axcor Spot 400 | 28 DMX | 28 | Rig SLR | 104 |
| 1.333 | Clay Paky | Axcor Spot 400 | 28 DMX | 28 | Rig SLC | 105 |
| 1.361 | Clay Paky | Axcor Spot 400 | 28 DMX | 28 | Rig SL | 106 |
| 2.286 | Robe | Robin DLX Spot | Mode 1, 35 DMX | 35 | Flex | 301 |
| 2.321 | Robe | Robin DLX Spot | Mode 1, 35 DMX | 35 | Flex | 302 |
| 2.356 | Robe | Robin DLX Spot | Mode 1, 35 DMX | 35 | Flex | 303 |
| 2.391 | Robe | Robin DLX Spot | Mode 1, 35 DMX | 35 | Flex | 304 |

STROBE

| Adress | Manufacturer | Fixture | Mode | Chan. | Position | Fixture ID |
|--------|--------------|-------------|-----------|-------|----------|------------|
| 1.211 | Martin | Atomic 3000 | 4 Channel | 4 | Rig SR | 3001 |
| 1.215 | Martin | Atomic 3000 | 4 Channel | 4 | Rig SL | 3002 |
| 2.219 | Martin | Atomic 3000 | 4 Channel | 4 | Flex | 3003 |

KIFF AARAU

LED PARS

| Adress | Manufacturer | Fixture | Mode | Chan. | Position | Fixture ID |
|--------|--------------|-----------------|-------|-------|----------|------------|
| 2.230 | Martin | Rush PAR 1 RGBW | 7 DMX | 7 | Flex | 401 |
| 2.237 | Martin | Rush PAR 1 RGBW | 7 DMX | 7 | Flex | 402 |
| 2.244 | Martin | Rush PAR 1 RGBW | 7 DMX | 7 | Flex | 403 |
| 2.251 | Martin | Rush PAR 1 RGBW | 7 DMX | 7 | Flex | 404 |
| 2.258 | Martin | Rush PAR 1 RGBW | 7 DMX | 7 | Flex | 405 |
| 2.265 | Martin | Rush PAR 1 RGBW | 7 DMX | 7 | Flex | 406 |
| 2.272 | Martin | Rush PAR 1 RGBW | 7 DMX | 7 | Flex | 407 |
| 2.279 | Martin | Rush PAR 1 RGBW | 7 DMX | 7 | Flex | 408 |
| 3.426 | Martin | Rush PAR 1 RGBW | 7 DMX | 7 | Audience | 1401 |
| 3.433 | Martin | Rush PAR 1 RGBW | 7 DMX | 7 | Audience | 1402 |
| 3.440 | Martin | Rush PAR 1 RGBW | 7 DMX | 7 | Audience | 1403 |
| 3.447 | Martin | Rush PAR 1 RGBW | 7 DMX | 7 | Audience | 1404 |
| 3.454 | Martin | Rush PAR 1 RGBW | 7 DMX | 7 | Audience | 1405 |
| 3.461 | Martin | Rush PAR 1 RGBW | 7 DMX | 7 | Audience | 1406 |
| 3.468 | Martin | Rush PAR 1 RGBW | 7 DMX | 7 | Audience | 1407 |
| 3.475 | Martin | Rush PAR 1 RGBW | 7 DMX | 7 | Audience | 1408 |
| 3.482 | Martin | Rush PAR 1 RGBW | 7 DMX | 7 | Audience | 1409 |
| 3.489 | Martin | Rush PAR 1 RGBW | 7 DMX | 7 | Audience | 1410 |
| 3.496 | Martin | Rush PAR 1 RGBW | 7 DMX | 7 | Audience | 1411 |
| 3.503 | Martin | Rush PAR 1 RGBW | 7 DMX | 7 | Audience | 1412 |

SUNSTRIPS

| Adress | Manufacturer | Fixture | Mode | Chan. | Position | Fixture ID |
|--------|--------------|---------------------|-------|-------|----------|------------|
| 2.001 | Showtec | Sunstrip Active DMX | CH:10 | 10 | Flex | 601 |
| 2.011 | Showtec | Sunstrip Active DMX | CH:10 | 10 | Flex | 602 |
| 2.021 | Showtec | Sunstrip Active DMX | CH:10 | 10 | Flex | 603 |
| 2.031 | Showtec | Sunstrip Active DMX | CH:10 | 10 | Flex | 604 |
| 2.041 | Showtec | Sunstrip Active DMX | CH:10 | 10 | Flex | 605 |
| 2.051 | Showtec | Sunstrip Active DMX | CH:10 | 10 | Flex | 606 |

QUAD PHASE

| Adress | Manufacturer | Fixture | Mode | Chan. | Position | Fixture ID |
|--------|--------------|---------------|-------|-------|------------------|------------|
| 3.079 | American DJ | Quad Phase HP | 4 DMX | 4 | Alley Audience L | 1101 |
| 3.083 | American DJ | Quad Phase HP | 4 DMX | 4 | Alley Audience R | 1102 |
| 3.087 | American DJ | Quad Phase HP | 4 DMX | 4 | FoH, Above | 1103 |

HAZER/SMOKE MACHINE

| Adress | Manufacturer | Fixture | Mode | Chan. | Position | Fixture ID |
|--------|---------------|-------------------|-------|-------|------------|------------|
| 1.219 | Smoke Factory | Tour Hazer II v.2 | 2 DMX | 2 | Floor SR | 60 |
| 3.226 | Smoke Factory | Data II | 2 DMX | 2 | FoH, Above | 70 |

FLEXIBLE (if not in use elsewhere)

| Adress | Manufacturer | Fixture | Mode | Chan. | Position | Fixture ID |
|--------|--------------|-------------|---------|-------|----------|------------|
| 3.319 | Cameo | TW 600 nr.1 | 7DMX m2 | 7 | Flex | 501 |
| 3.326 | Cameo | TW 600 nr.2 | 7DMX m2 | 7 | Flex | 502 |
| 3.333 | Cameo | TW 600 nr.3 | 7DMX m2 | 7 | Flex | 503 |
| 3.340 | Cameo | TW 600 nr.4 | 7DMX m2 | 7 | Flex | 504 |
| 3.301 | | UV Gun | | 1 | Flex | 511 |
| 3.302 | | UV Gun | | 1 | Flex | 512 |

SPARE DMX CHANNELS

| | | |
|------------|---------|----------------------|
| Universe A | 019-024 | <i>not available</i> |
| Universe A | 049-060 | <i>not available</i> |
| Universe A | 145-210 | |
| Universe A | 389-512 | |
| Universe B | 061-218 | |
| Universe B | 223-229 | |
| Universe B | 426-512 | |
| Universe C | 001-078 | |
| Universe C | 091-225 | |
| Universe C | 228-300 | |
| Universe C | 303-318 | |
| Universe C | 347-425 | |
| Universe C | 510-512 | |
| Tieline A | 001-512 | |
| Tieline B | 001-512 | |







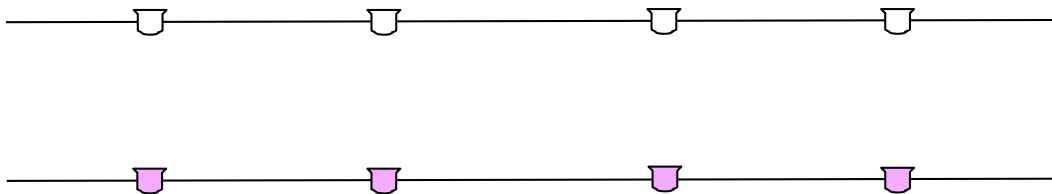
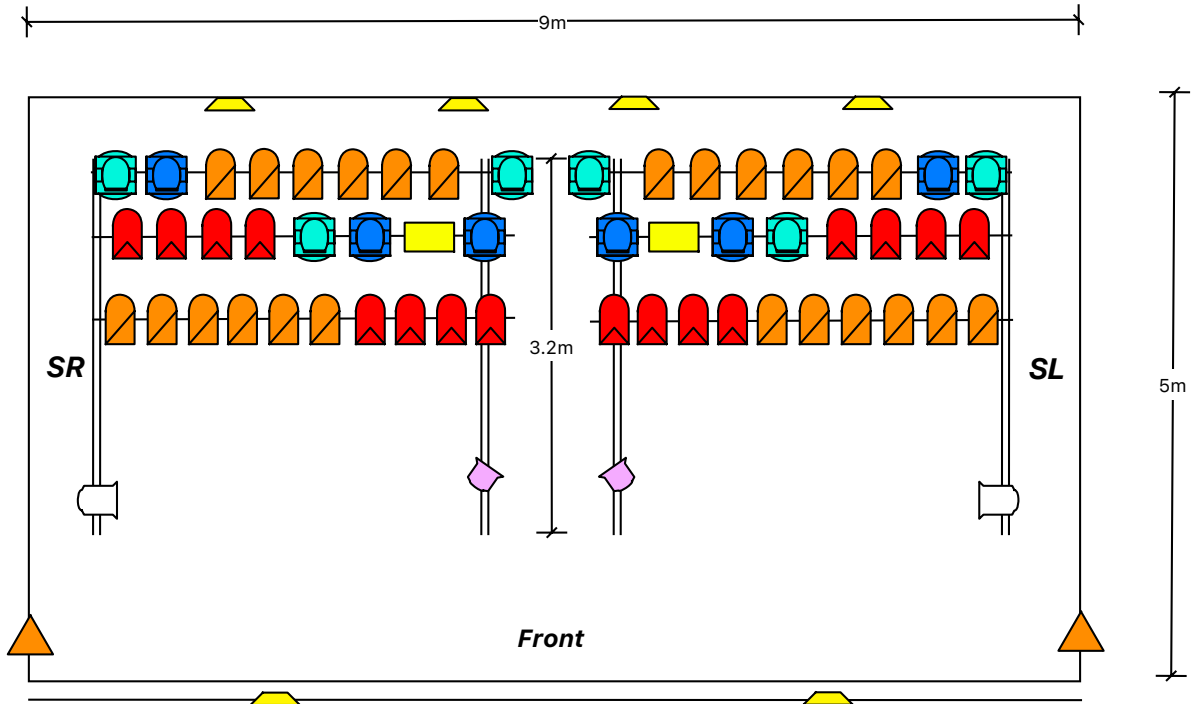

KIFF

AARAU

Light Plot 2024



Legende:

- | | | | | | | | | | |
|---|---|---|---|---|---|---|---|---|---|
|  |  |  |  |  |  |  |  |  |  |
| Fresnel 2kW | Fresnel 1kW | Fresnel 500W | PAR64 NSP | ACL | Blinder | Strobe | Spot | Wash | Sidelight |